



# **SPEAKMAN<sup>®</sup>** **SENSORFLO<sup>®</sup>** **FLUSH VALVES**

Upgrade Restrooms For A More Hygienic Environment

For 150 years, Speakman products have elevated the design and performance of hotels and commercial projects around the globe. SENSORFLO<sup>®</sup> fixtures are hygienic, sensor operated fixtures that are designed and engineered in accordance with the highest quality and performance standards. Utilizing the most up-to-date laser technology, SENSORFLO<sup>®</sup> fixtures provide reliable and efficient sensor activation.



Durable, dependable and long-lasting: SENSORFLO® Flush Valves from Speakman deliver commercial-grade performance you can count on. Built using Speakman's proven sensor technology, each water closet and urinal valve is designed for low maintenance from install to service life.

# SENSORFLO®

## EXPOSED SENSOR URINAL PISTON FLUSHOMETER

### BATTERY / HARDWIRED

#### Battery Specific Features:

- Battery powered (4x standard AA alkaline batteries, included)
- 300,000 cycles (4 years) battery

#### Hardwired Specific Features:

- Hard-wired (with included 4x AAA alkaline battery backup)
- Backup battery: 100,000 cycles (1 year)

#### Overall Features:

- Piston valve
- Yellow brass valve body material
- Top spud fixture connection
- 11 1/2" (292mm) rough-in Dimension
- 3/4"-14 NPSM spud coupling
- 3/4"-14 NPT supply pipe
- 3/4" sweat solder adapter with cover tube and escutcheon
- Manual override stem seal, piston cup seal washer, piston sealing washer, stop-body plunger seal, and tailpiece O-ring are molded from chloramine resistant rubber compound
- 2 to 3 second flush delay
- Low battery indicator: Light on sensor window flashes once per second when low, and twice per second when critically low
- Fixed volume bypass with no external adjustment
- Override button located on side of unit
- 3/4" NPT check-stop, adjustable with flat-tipped screwdriver
- Check-stop cap is secured with a set screw for vandal resistance
- Infrared sensor that detects movement 2 feet away and in a 15° vertical sweep
- Operating Pressure: 20 to 80 PSI (138 to 552 kPa)
- Operating Temperature: 50 to 110 °F (10 to 43 °C)

#### STANDARDS:

- ASME A112.1037/CSA B1255.37 certified
- ASSE 1037 certified
- WaterSense certified models: SV-3005 & SV-3105
- ADA compliant

#### 5 Year Limited Warranty (commercial)



**0.5 GPF**  
SV-3005  
SV-3010



**0.5 GPF**  
SV-3005  
SV-3010

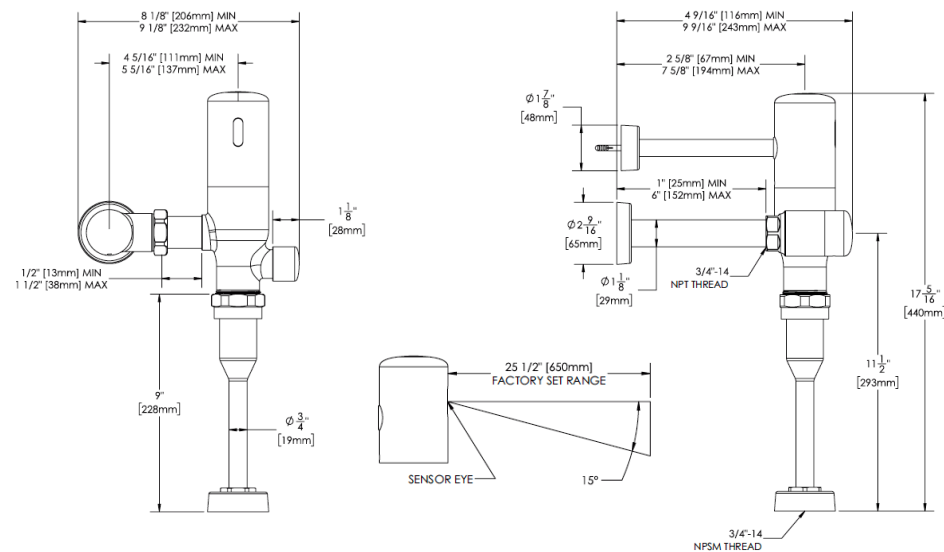

Vandal-resistant features and rugged components keep high-traffic bathrooms clean, sanitary and usable. Available in configurations to meet a variety of application needs, including full battery operation or hardwired with battery backup. Speakman's flush valves can fit any application and ensure that your clients can provide a clean, safe bathroom environment.



# SENSORFLO®

## EXPOSED SENSOR WATER CLOSET PISTON FLUSHOMETER

### BATTERY / HARDWIRED

#### Battery Specific Features:

- Battery powered (4x standard AA alkaline batteries, included)
- 300,000 cycles (4 years) battery

#### Hardwired Specific Features:

- Hard-wired (with included 4x AAA alkaline battery backup)
- Backup battery: 100,000 cycles (1 year)

#### Overall Features:

- Piston valve
- Yellow brass valve body material
- Top spud fixture connection
- 11 1/2" (292mm) rough-in Dimension
- 1 1/2"-1 1/2" NPSM spud coupling
- 1"-1 1/2" NPT supply pipe
- 1" sweat solder adapter with cover tube and escutcheon
- Manual override stem seal, piston cup seal washer, piston sealing washer, stop-body plunger seal, and tailpiece O-ring are molded from chloramine resistant rubber compound
- 2 to 3 second flush delay
- Low battery indicator: Light on sensor window flashes once per second when low, and twice per second when critically low
- Fixed volume bypass with no external adjustment
- Manual override button located on side of unit
- 1" NPT check-stop, adjustable with flat-tipped screwdriver
- Check-stop cap is secured with a set screw for vandal resistance
- Infrared sensor that detects movement 2 feet away and in a 15° vertical sweep
- Operating Pressure: 20 to 80 PSI (138 to 552 kPa)
- Operating Temperature: 50 to 110 °F (10 to 43 °C)

#### STANDARDS:

- ASME A112.1037/CSA B1255.37 certified
- ASSE 1037 certified
- WaterSense certified models: SV-4012 & SV-4128
- ADA compliant

#### 5 Year Limited Warranty (commercial)



**1.28 GPF**

SV-4012  
SV-4016



**1.6 GPF**

SV-4116  
SV-4128

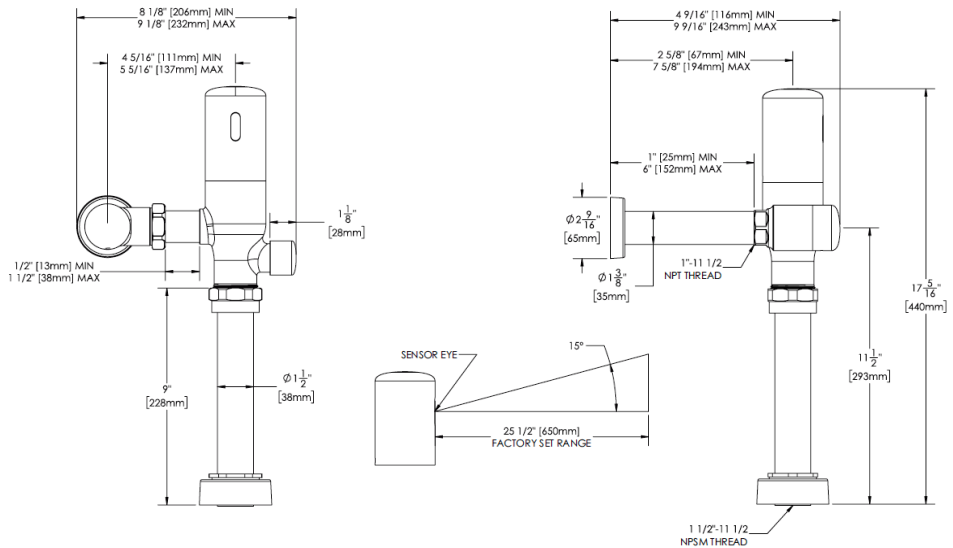

Touchless solutions by Speakman promote a hygienic environment for commercial restrooms. You can complete the entire commercial restroom specification with Speakman. In addition to our flush valves, we offer an entire line of sensor-operated faucets, soap dispensers, combination units and deck plates. Whether you are completing a renovation, new construction build or retro-fitting for touchless, there is a Speakman SensorFlo fixture to meet the design and demands of the restroom. Trusted by hotels for engineering commercial plumbing solutions for over 150 years – the experience speaks for itself.



SF-8700 / SF-8700-TMV  
**Battery Powered Sensor Faucet**  
 TMV = Thermostatic Mixing Valve



SFC-8790  
**Low Arc Sensor Faucet and Soap Combination**



SFS-8000  
**Classic Sensor Soap Dispenser**

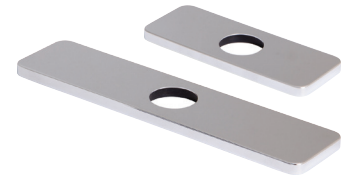

SF-4DECK & SF-8DECK  
**4" & 8" Deck Plate for SF-8700**



SF-9700 / SF-9700-TMV  
**Battery Powered Designer Series Sensor Faucet**  
 TMV = Thermostatic Mixing Valve



SFC-9790  
**Designer Series Sensor Faucet and Soap Combination**



SFS-9000  
**Designer Sensor Soap Dispenser**



SEF-4DECK & SEF-8DECK  
**4" & 8" Deck Plate for SF-9700**



SF-9100 / SF-9100-TMV (Battery)  
 SF-9200 / SF-9200-TMV (AC)  
**Gooseneck Sensor Faucet**  
 TMV = Thermostatic Mixing Valve



SF-9202 (AC)  
**Gooseneck Sensor Faucet w/ Above Counter Mixer**



SF-9107 / SF-9107-TMV (Battery)  
 SF-9207 / SF-9207-TMV (AC)  
**Gooseneck Sensor Faucet w/ Manual Override**



SF-1000 / SF-1000-TMV  
 SF-2000 / SF-2000-TMV  
**Wall Mounted AC Powered Sensor Faucet**

## WARRANTY

**5 Year Limited Warranty:** Speakman commercial and hospitality plumbing products are warranted to be free of defects in material and workmanship for 5 years from date of installation. ("Warranty Period"). Speakman warrants to its purchasers only ("Buyer") that goods are sold free from defects in materials and workmanship and conform to Speakman's specifications at the time of manufacturing, provided the goods are properly installed and maintained. Buyer's sole and exclusive remedy for any goods that may prove to have had a non-conformance within the Warranty Period shall be, at Speakman's sole option, the repair or replacement of the non-conforming goods.

**SPEAKMAN®**

[www.speakman.com](http://www.speakman.com)

# SPK-Sensorflo-FlushValvesBro-21